

This Application Note is pertinent to the Quantum MP Family

### Quantum MP with Motorized Potentiometer (MOP)

There are many applications that use a MOP (Motorized Potentiometer) to adjust the speed of their machine. This consists of an Increase and decrease pushbutton located on the Operators Control Station. An example might be an Extruder. The QMP in its default state is very easy to re-configure for this. Below is the default set up of the QMP and its associated parameter list. We will use the existing Jog input for the Increase pushbutton and the Fwd / Rev input for the Decrease pushbutton.

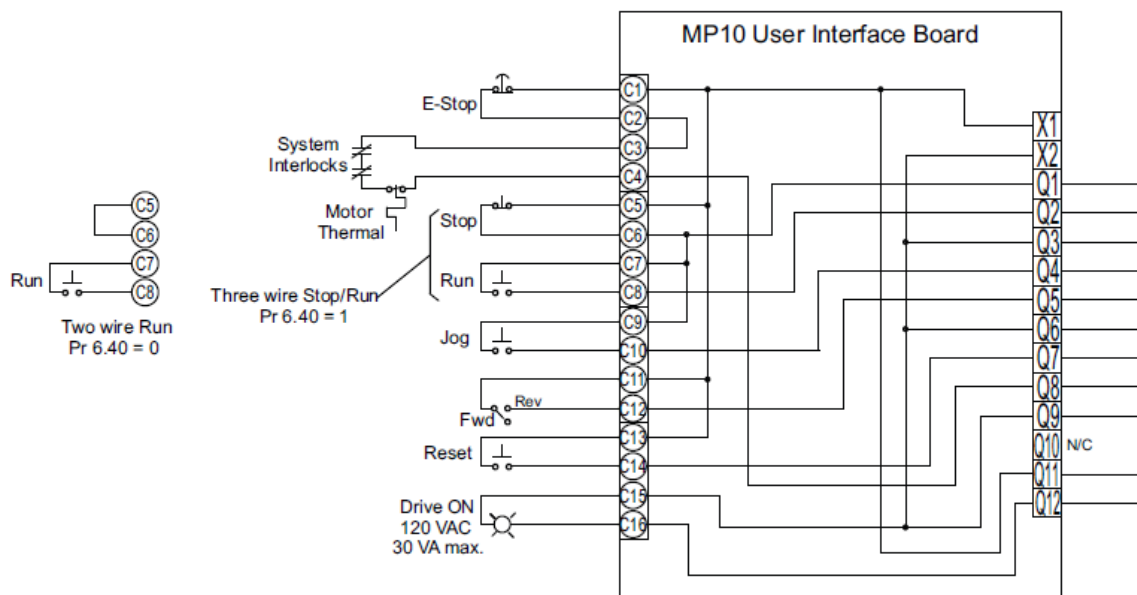

Parameter	QMP Value	Description
5.16	1	Selects Armature Voltage from motor side of the contactor
6.40	1	Enable sequencer latching
8.22	0.00	Disable T25 digital I/O 2 source / destination <b>on Mentor MP</b>
8.23	0.00	Disable T26 digital I/O 2 source / destination <b>on Mentor MP</b>
8.24	0.00	Disable T27 digital I/O 2 source / destination <b>on Mentor MP</b>
8.26	0.00	Disable T29 digital I/O 2 source / destination <b>on Mentor MP</b>
9.04	17.06	External Trip input from e-stop / system interlock loop – C4 input (120vac)
9.05	1	Logic Function 1 - Invert Terminal C4
9.09	0.1	Logic Function 1 - Time delay for external trip input
9.10	10.32	Logic Function 1 - Destination of C4 Input (external trip)
9.37	1	Set Logic Function 1 to "OR" gate
17.21	6.39	T1 SM-I/O 120 digital input destination – Not Stop
17.22	6.34	T2 SM-I/O 120 digital input destination – Run
17.23	6.31	T4 SM-I/O 120 digital input destination – Jog
17.24	6.33	T5 SM-I/O 120 digital input destination – Forward / Reverse
17.25	10.33	T7 SM-I/O 120 digital input destination – Drive reset
17.28	6.55	Relay 2 source – Contactor enable

### Analog Input 1

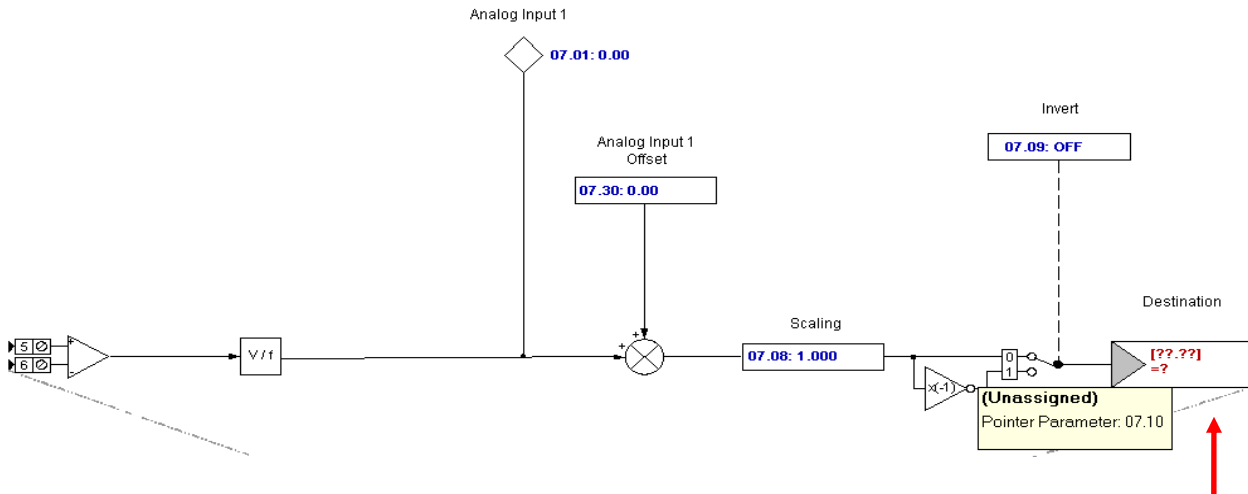

Step 1 is to disconnect the default analog input destination by setting #7.10 = 0.00

### Motorised Potentiometer Function

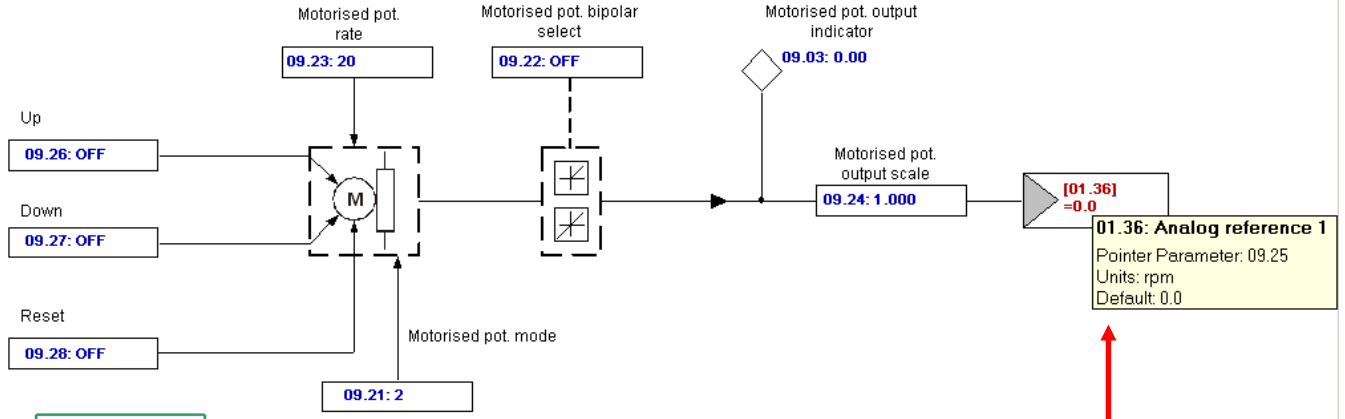

Step 2 is to connect the output of the MOP function to the speed reference register #9.25 = 1.36

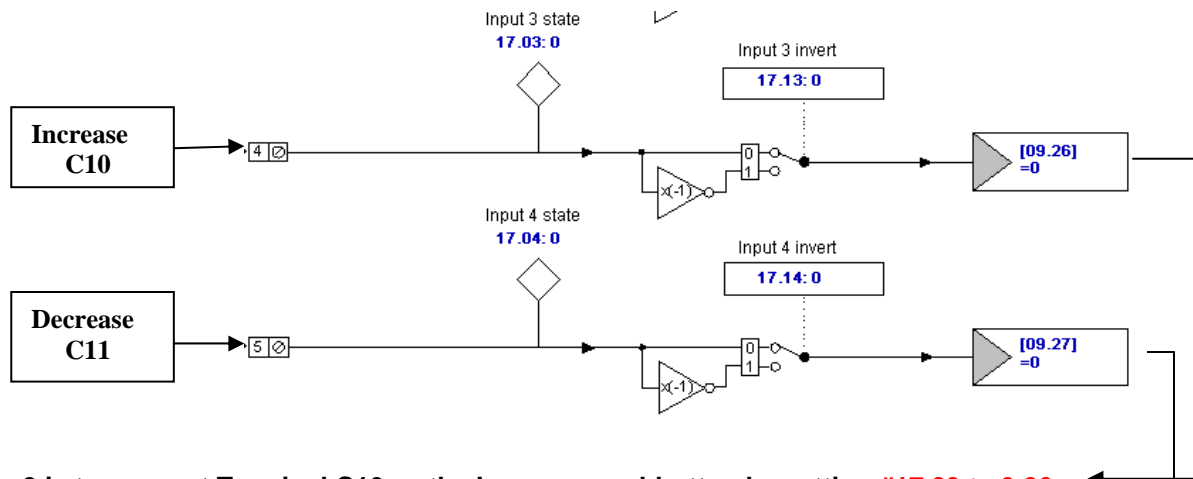

Step 3 is to connect Terminal C10 as the Increase pushbutton by setting #17.23 to 9.26  
Terminal C11 as the Decrease pushbutton by setting #17.24 to 9.27

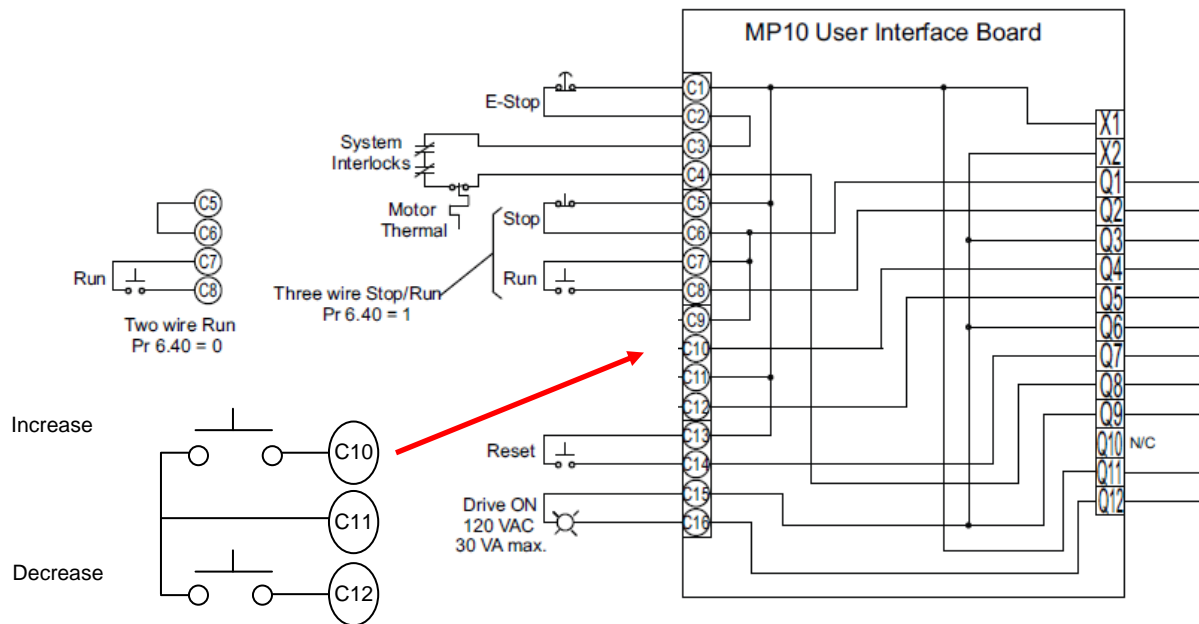

Parameter	QMP Value	Description
5.16	1	Selects Armature Voltage from motor side of the contactor
6.40	1	Enable sequencer latching
8.22	0.00	Disable T25 digital I/O 2 source / destination <b>on Mentor MP</b>
8.23	0.00	Disable T26 digital I/O 2 source / destination <b>on Mentor MP</b>
8.24	0.00	Disable T27 digital I/O 2 source / destination <b>on Mentor MP</b>
8.26	0.00	Disable T29 digital I/O 2 source / destination <b>on Mentor MP</b>
9.04	17.06	External Trip input from e-stop / system interlock loop – C4 input (120vac)
9.05	1	Logic Function 1 - Invert Terminal C4
9.09	0.1	Logic Function 1 - Time delay for external trip input
9.10	10.32	Logic Function 1 - Destination of C4 Input (external trip)
9.37	1	Set Logic Function 1 to “OR” gate
17.21	6.39	T1 SM-I/O 120 digital input destination – Not Stop
17.22	6.34	T2 SM-I/O 120 digital input destination – Run
17.23	9.26	T4 SM-I/O 120 digital input destination – Jog
17.24	9.27	T5 SM-I/O 120 digital input destination – Forward / Reverse
17.25	10.33	T7 SM-I/O 120 digital input destination – Drive reset
17.28	6.55	Relay 2 source – Contactor enable
7.10	0.00	Disconnect analog input 1
9.25	1.36	Connect MOP output to speed register 1.36
17.23	9.26	Connect Increase
17.24	9.27	Connect Decrease
9.21	2	MOP Mode – see below
9.22	Off	Bi-polar output select
9.23	20	MOP rate – default 20 seconds to max output – Should be set slower than drive acceleration and deceleration rates

**Mop Modes –**

- 0 = Zero output at Power-up
- 1 = Last value at Power-up
- 2 = Zero at Power-up and only change while drive is running
- 3 = Last value at Power-up and only change while drive is running

**Questions:** Ask the author??  
 Steve Zaleski Email: <mailto:steve.zaleski@emerson.com>

Tel: 800-367-8067